

FRONT VIEW

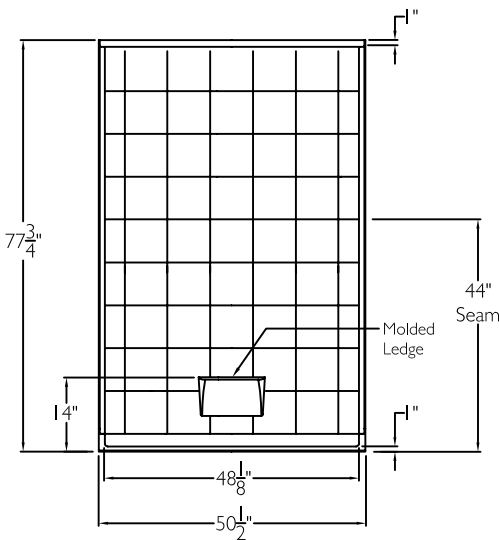

SIDE VIEW

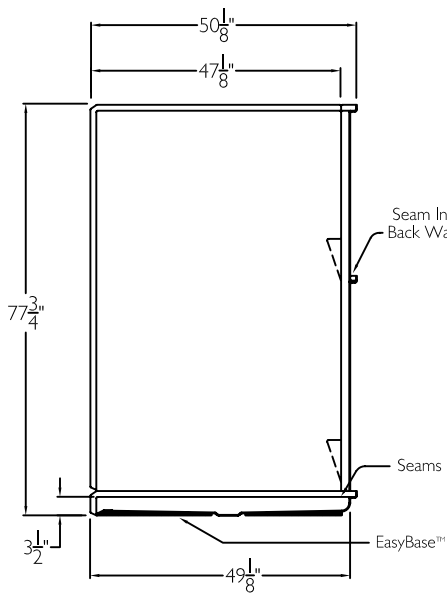

CROSS SECTION OF THRESHOLD

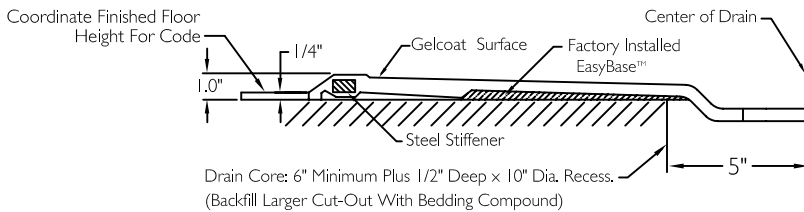

TOP VIEW

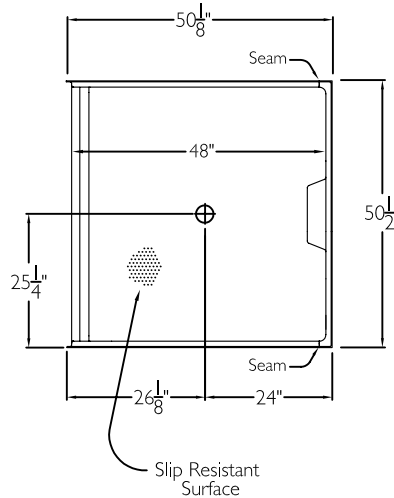

SUBMITTAL

This shower enclosure shall be model XST 5050 BF 5P 1.0" center. Finished surface shall be of a sanitary grade polyester gelcoat exhibiting a minimal thickness of 15 dry mils and a finished cured Barcoal hardness of 80-90 as tested with ASTM D-2583. Unit construction shall be of a molded reinforced fiberglass with a 15% minimum fiberglass content.

The unit shall have outside dimensions of 50 1/2" x 50 1/8" x 77 3/4".

The unit shall meet ANSI Z124.1-2. HUD, BOCA, NAHB, UPC, and shall meet the requirements of the Southern Building Code.

The enclosure shall be equipped with the following accessories:

- 1) Five piece sectional design,
- 2) one molded ledge low on the back wall,
- 3) tile finish
- 4) full wood backing on all walls,
- 5) Self locating aluminum guide pin wall interlocking system,
- 6) low profile, 1.0" change of level threshold,
- 7) EasyBase™ self sustaining bottom.

THIS UNIT FEATURES THE OUTSIDE DIMENSION OF 50 1/2" OF OVERALL WIDTH. THIS DOES NOT ALLOW FOR FULL ENCLOSURE OF THE BOLTS AND NUTS USED TO SECURE THE BARS AND SEAT IN PLACE. THE BOLT AND NUT COMBINATION SHOULD NOT PROTRUDE MORE THAN 3/4" ON EITHER SIDE OF THE SHOWER WALLS. THIS MAY REQUIRE THE NEED TO NOTCH STUDS TO ALLOW BOLT CLEARANCE FOR A DRYWALL ENCLOSED FIRE WALL INSTALLATION. ADJUSTMENT OF THE WALL BOARD MAY BE NECESSARY TO PROVIDE CLEARANCE OF THE BOLT(S) WHILE MAINTAINING THE INTEGRITY OF THE DRYWALL

Job Name	Approved By	Name	Date	COMFORT DESIGNS	
Project No	Architect			Model No.	XST 5050 BF 5P 1.0 C-I
Comfort Designs 435 Industrial Road Savannah, TN 38372 tel 800.443.7269 fax 731.925.4290 www.comfortdesignsbathware.com	Engineer			Drawing No.	XST 5050 BF 5P 1.0 FWB EB
	Rep			Date Issued.	6-18-12
	Wholesaler			Drawing Rev.	8-27-13
	Comments				Material.
				Color.	
				Dimensions are in inches. Due to the nature of the materials dimensions may vary ± 1/2"	